

# GKR bevel gearboxes

## General information



### Product key

Mounting position (A...F) and position of system blocks (1...6)

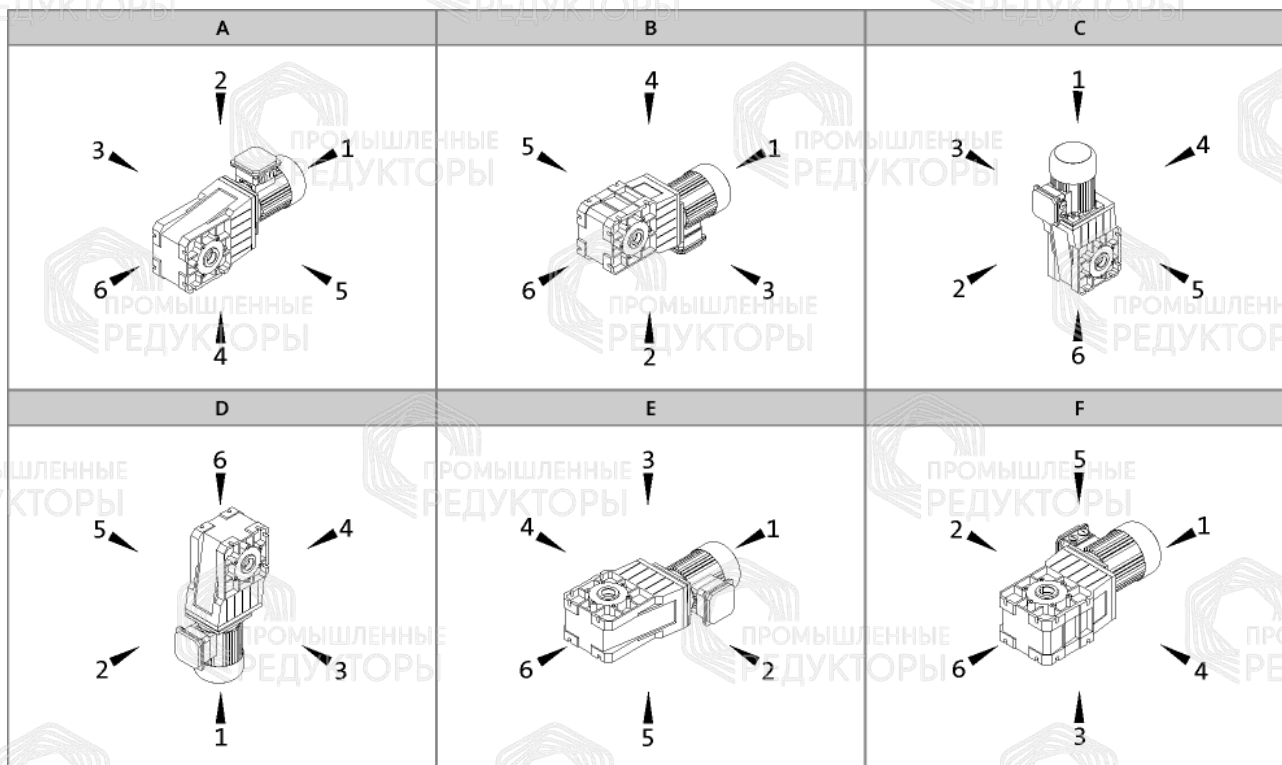

Hollow shaft: 0  
 Solid shaft: 3, 5, 8 (3+5)  
 Hollow shaft with shrink disc: 3, 5

Without flange: 0  
 Flange: 3, 5, 8 (3+5)  
 Terminal box / motec: 2, 3, 4, 5

### Gearbox designs

Basic versions	
Motor efficiency	Standard efficiency Increased efficiency (IE2)
Surface and corrosion protection	No OKS (unpainted, aluminium housing) OKS-S (paint: RAL 7012)
Lubricant	CLP 460 (mineral)
Ventilation	Breather elements for GKR06

Options	
Surface and corrosion protection	OKS-G (primer: grey) OKS-S (special paint according to RAL) OKS-M (special paint according to RAL) OKS-L (special paint according to RAL)
Lubricant	CLP HC 320 (synthetic) CLP HC 220 USDA H1 (synthetic)
Shaft sealing rings	Driven shaft: Viton
Accessories	Rubber buffer for torque plate (GKR 03/04 only) Torque plate on threaded pitch circle Housing foot torque plate (GKR05/06 only) 2nd output shaft end Shrink disc cover Hoseproof hollow shaft cover Mounting set for hollow shaft circlip
Nameplate	Metal nameplate (supplied loose) Adhesive nameplate (supplied loose)